



ADDENDUM:

**Investigation into the performance of
Statistics House in the 14 November 2016
Kaikōura Earthquake**

June 2018



Executive summary

In March 2018 the Statistics House Expert Panel was reconvened to review new information discovered during the demolition of Statistics House in December 2017 and January 2018. The Panel was presented with evidence that showed in a number of instances the seating provided for precast concrete floor units was less than the 50mm minimum specified on the design documentation.

The presence of the short seatings of the precast concrete floor units does not change the Panel's conclusions that the partial floor collapses were caused primarily by a combination of a highly flexible ductile frame, beam elongation, shortening of the precast concrete floor units, amplification of ground shaking and the duration of the earthquake.

The observed short seatings were part of a precast concrete floor system including loop bar hangers, and the Panel confirms its earlier conclusion that the loop bar hanger connection was a key contributor to the failure during the November 2016 Kaikōura earthquake as it led to the premature shortening of the precast floor units. The Panel cannot conclude that the end bay units that fell during the earthquake had less than the specified seating. If present in those units, short seating may have hastened the failure sequence.

A number of instances of non-conformance with the Building Code were identified in the earlier investigation. The new evidence confirms that the as-built seating width was not in accordance with either the Concrete Structures Standard or the Concrete Construction Standard of the day. The Panel is of the view that this is a result of the combination of inadequate allowance for construction tolerances and the geometry of the precast flooring system.

The Panel has concluded that the progressive collapse of the flooring during demolition (which was the trigger for this report) should be taken into account in reviewing industry approaches to the assessment of existing buildings. However, the mitigation measures to be taken (if required) should address the primary failure mechanism as noted above.

Photographic and other evidence obtained during the demolition has reinforced the Panel's opinion that the ease with which this building type (seismic moment-resisting frame with precast concrete components) can be demolished should alert designers, building owners and demolition contractors to building performance issues for both earthquake load conditions and demolition considerations.

The Panel finally concluded that the industry approach to construction tolerances requires review, taking into account the sequence of casting and erection of precast concrete elements.

Introduction

This document is an addendum to the *Investigation into the Performance of Statistics House in the 14 November 2016 Kaikōura Earthquake* report, published by the Ministry of Business, Innovation and Employment (MBIE) in March 2017. This addendum should be read in conjunction with the original report. The original expert Panel was reconvened in March 2018 to review new information provided by the engineering consultant engaged to monitor the demolition of Statistics House. The Terms of Reference for this review is included in Annex A along with the relevant correspondence from the engineering consultants (Annex B).

The panel members are:

- Dr Helen Anderson (Chair)
- John Hare
- Rick Wentz

Biographies of the panel members were included in the original report.

The Panel reviewed photographic, video and written material relating to the demolition of Statistics House. The Panel did not seek to determine culpability or liability arising from the November 2016 collapse.

The Panel's overall conclusions from the original investigation (p2) noted that "the partial floor collapses at Statistics House were caused by a combination of:

- a highly flexible ductile frame with two bays of frame per precast floor span, which effectively doubled the impact of beam elongation due to plastic hinging; and
- shortening of the precast double-tee flooring units as the ends spalled during the earthquake; and
- amplification of ground shaking, primarily due to basin-edge effects in the Thorndon basin area; and
- the duration of the earthquake.

The combination of these effects was not anticipated by the New Zealand design Standards recognised in the Building Code at the time of the design of Statistics House."

This addendum takes the following into account:

- the letter to MBIE (Annex B) from the demolition engineering consultant firm
- relevant documentation from the demolition process
- interviews with representatives of the demolition contractor, demolition engineering consultant, original structural design engineer, original main contractor and the building owner.
- the review of original design documentation, including shop drawings.

A technical annex (Annex C) providing more detailed commentary is included with this Addendum.

Observations made during the demolition of Statistics House

■ Demolition collapse sequence

The demolition process began on 27 December 2017. The demolition engineers monitoring the demolition were regularly, but not continuously, on site during the demolition. They provided regular reports to the demolition contractors and had reviewed the demolition methodology prior to the start of demolition.

Following the first day of demolition, which began at the southwest corner of the building, the methodology was revised. In their letter to MBIE the demolition engineers noted that the

methodology change was “in part necessitated by the uncontrolled collapse of the double-tee floor units ...”

The demolition contractors advised the Panel that the methodology changed for a number of reasons, including the presence of a gas bottle hazard in the southeast corner, strong winds and maintaining road access to the south. They consider that the demolition process progressed as expected, given their experience demolishing several buildings of similar design and construction in New Zealand.

The demolition contractors told the Panel that precast double-tee floor elements are relatively simple to demolish and that once one floor unit is dropped onto the floor below the lower units often collapse as a sequence.

The same demolition engineers and contractors had been involved in the demolition of the Reading Cinema car park, which also had precast double-tee floor units. The engineers’ view was that, in contrast to the Reading Cinema car park, the Statistics House demolition involved unusual and “uncontrolled collapse”, which they observed on 27 December 2017. The demolition contractors told the Panel that the demolition process at the Reading Cinema car park involved multiple instances of progressive floor collapse, and they did not regard that as unexpected or unusual. It is understood that the double-tee system in use at the Reading Cinema car park differed from Statistics House in using ribs at 600mm centres (instead of 1200mm) and possibly in using a different support system. However, the general behaviour during demolition was reportedly similar.

On the basis of these different opinions and observations the Panel is unable to conclude that the demolition process of Statistics House was indicative of an ‘uncontrolled’ collapse, or that it was unusual for buildings with flange-supported double-tee flooring systems. It may be better characterised as a progressive collapse of the floors as a consequence of the demolition process.

■ Evidence of precast concrete floor unit seatings

The demolition engineers examined some of the precast concrete beams following their removal from the building. They were not able to examine the inside of the building prior to demolition, and during the demolition they were only able to access beams and columns that had been stockpiled prior to further processing. The exact location of where the beams were in the building prior to being removed was not recorded by the demolition engineer or contractor. The demolition engineers noted that there were no identifiable intact precast flooring units as these typically break up easily during demolition.

The Panel was advised by the demolition engineers that they sought to measure a range of precast floor unit seatings by examining the stockpiled beams. The demolition engineers noted variability in the measured precast concrete floor unit seating (they report a range from 38mm to 120mm) and their opinion was that around 50 per cent of the measured seatings were less than 50mm. These seatings are less than the prescribed minimum shown in the design documentation and less than that required by the Concrete Structures Standard of the day (60mm for the outer bays).

The Panel was unable to conclude what the prevalence of short seatings was because the location and the number of beams removed and measured were not accurately recorded. However, the Panel is confident that the photographs provided typically show details from the junction of the beams, precast floor unit and associated in-situ topping, indicating that short precast concrete floor unit seating did occur.

Significance of observations made during the demolition of Statistics House

■ Significance of design and construction tolerances

The Panel's opinion is that the short seatings were largely a consequence of construction tolerances in combination with the geometry of the double tee and its flange supports. The Panel notes that the sequence of shop drawing, fabrication of precast elements and the construction of the supporting frames (for the floors) does not allow adjustment of the precast lengths to suit the as-built location of the supporting frames. This is particularly critical for flange-supported double-tee units

The general construction sequence of precast concrete systems necessitates careful consideration of construction tolerances. Precast concrete components, which are generally constructed off-site under controlled conditions, must be integrated with components constructed under less favourable conditions. Sufficient allowance must be made for general construction inexactness, to ensure that precast concrete elements brought to site are likely to fit and not be damaged during installation.

Tolerances related to the construction and erection of concrete structures are generally specified in NZS3109:1997¹, which describes how precisely the structure must be built relative to the design drawings. In contrast, the Concrete Structures Standard for design, NZS3101:1995², states that the seating of flooring units must be designed to include allowance for "a reasonable combination of unfavourable tolerances", without specifying in particular what a "reasonable combination" is (refer to Appendix A of Annex C). The apparent inconsistencies in the way these two governing Standards treat construction tolerances is further discussed in Annex C. It should be noted that NZS3101:1995 has been updated since the construction of Statistics House, including modifications to the provisions for seating of floor systems. This updated version of NZS3101:1995 is now cited in the most recent amendment (April 2018) to the Verification Method B1/VM1 that provides a means of demonstrating compliance with the structural provisions of the New Zealand Building Code.

■ Significance of short precast concrete floor unit seatings

The impact of the precast concrete floor unit seatings being less than specified in the Concrete Structures Standard of the day (by up to 22mm) is difficult to quantify.

First, the impact of beam elongation in the north and south frames was largely restricted (by other design detailing) to the end bays of the east and west frames only. Most other seatings would not have suffered significant elongation or tension actions pulling the double tee from the support.

¹ Standards New Zealand, NZS3109:1997, Concrete Construction – This Standard provides a means of compliance with the construction requirements for concrete structures designed in accordance with NZS3101.

² Standards New Zealand, NZS3101:1995, Concrete Structures Standard, Part 1, The Design of Concrete Structures & Part 2, Commentary on the Design of Concrete Structures – This Standard sets out the minimum requirements for the design of reinforced and pre-stressed concrete structures. The Standard is cited as a means of compliance with Clause B1: Structure of the New Zealand Building Code through Verification Method B1/VM1.

Even if the required seating had been achieved, the failure mode of the units that collapsed during the Kaikōura earthquake is likely to have been similar, or no different, as it was governed by the failure of the concrete around the loop bar hanger. Sufficient length of projection of the loop bar over the support is almost physically impossible due to its geometry (see Annex C). This is a unique feature of double tees with the loop bar supports, which are highly susceptible to damage.

Had the flooring system used a full depth support (web-supported double tees) or an alternative support system, such as a Cazaly hanger, an increased seating length would be much more effective, and achieving the specified seating may have delayed the failure during the Kaikōura earthquake.

Similarly, increasing the seating length for this form of support may have slightly improved performance of the loop bar supports during demolition. However, it would not have prevented the form of collapse observed, which was most likely due to tensile failures at the junction of the double-tee floor unit and the concrete topping over the loop bar supports (see Annex C). Again, another form of support would make the increased seating length more effective.

Note that the seating length required by the Concrete Structures Standard has increased significantly since the design of Statistics House and MBIE has issued a warning against the use of the loop bar hanger. These measures have improved the life safety performance of buildings but do not prevent damage that may not be practically repairable.

■ **Significance of impact loading and progressive collapse**

The Panel has considered the implications of the observed progressive floor collapse during demolition that appears to have resulted from the combination of impact loading and overloading due to accumulated demolition debris, along with the increased vulnerability of some floor units due to short seating or existing earthquake damage. The potential for progressive collapse could impact new building design as well as the assessment of the vulnerabilities of existing buildings.

In order for a progressive collapse to be initiated, there first has to be a failure of the support due to another cause. In the event of earthquake, this would most likely be similar to the primary mechanism of failure identified in the first report, assuming loop bars are used, or simply due to frame dilation if loop bars are not used. In that case, it is almost certain that the floors adjacent to the failed floor units would likely be in a similar condition, ie failure of the floor support due to frame dilation would be imminent. The shock loading may ultimately result in failure of the floors below the first unit to fail, but the frame dilation from earthquake loading would still be the root cause for the floor system losing its support. Therefore, it is critical for both the design and assessment of buildings that the primary failure mechanism is mitigated in the first instance, which then effectively mitigates the likelihood of progressive collapse under extreme loading events (not including demolition).

Secondary observations

■ **Retrofit brackets**

The demolition engineers advised the Panel that they observed some unexpected performance of the retrofit brackets during the demolition. The Panel notes that the demolition process imparts actions that are very different to those for which the brackets were designed. Therefore, it was unable to conclude that the brackets performed in an unexpected way. The Panel provides some further comment in the attached technical annex on the retrofit brackets (Annex C).

■ Non-conformances

In the initial report the Panel noted that there were a number of non-conformances (p20). It is important to note that the presence of a single, or even multiple, non-conformance does not directly result in the non-performance (eg structural failure) of a building. The Panel considered only those non-conformances that it considers material to the performance of this building, consistent with the Terms of Reference of the initial investigation.

During the initial investigation the Panel identified that there was some uncertainty about the support system for the precast floor units (p25) but it was unable to confirm the as-built dimensions. The evidence shown to the Panel confirms that, in a number of instances, the seating did not conform to the requirements of the design standard of the day. Other than the short seatings revealed during the demolition process, the Panel is not aware of any new non-conformances of significance to the failure during the Kaikōura earthquake.

■ Column C11

The demolition engineers drew specific attention to the behaviour of the corner columns, represented in particular by Column C11, which was in the northwest corner where the floor collapse occurred during the Kaikōura earthquake. A pattern of cracking was observed in the adjacent in-situ beam joint during the demolition process, which was consistent with a failure that could be due to non-conformant detailing.

It is of note that the partial floor collapse during the Kaikōura earthquake was generally due to actions in the east–west direction, whereas this joint would have been most vulnerable to north–south actions. Although there was evidence of movement and the onset of damage in the north–south direction (on the west and east frames) it was not indicative of the sort of movement that would have caused the damage observed at Column C11 during demolition.

While the detailing in this joint may not have met the requirements of the Concrete Structures Standard of the day, the Panel is unable to conclude that it had a significant influence on the partial collapse during the Kaikōura earthquake and cannot determine when in the earthquake and demolition sequence the observed damage occurred.

Conclusions and implications

The Panel's key conclusions from the original investigation (p2) noted that “the partial floor collapses at Statistics House were caused by a combination of factors. The primary cause was beam elongation in the transverse moment-resisting frames that provided the building's seismic resistance, exacerbated by a multiple bay frame arrangement”. The new evidence provided does not change the Panel's opinion of this primary cause of failure. However, if the short seatings were as prevalent as suggested, in particular in the end bays, then it is possible that the floor collapse sequence may have been hastened.

It was difficult to establish what damage occurred during the earthquake as distinct from the demolition process. The Panel was provided with photographic evidence of some damage to columns and beams that could be interpreted as damage from the earthquake, but because this was observed part way through the demolition process, the Panel was not sufficiently confident to consider this as new evidence of the seismic performance of the building.

The Panel considers that although progressive floor collapse is a potentially significant issue with regard to demolition safety, it is an outcome of the primary failure mechanism of loss of support to the floors. This is an issue that needs to be addressed in the design of new buildings, the

seismic assessment of existing buildings and in the post-earthquake damage evaluation of buildings. The Panel's view is that building owners should be encouraged to retrofit precast concrete floor systems because of their heightened vulnerability to frame dilation, not because of the secondary issues around progressive collapse in the event that frame dilation causes failure of one floor. Provided that new buildings are designed, detailed and constructed in accordance with the Building Code, the probability of loss of support should be acceptably low.

Precast concrete floor units are generally manufactured before the supporting elements are cast into position on-site so it is important to make sufficient allowance for construction tolerances. However, there are some apparent inconsistencies between the two governing Standards that may require review, given the general construction sequence of the concrete elements incorporating precast components.

Secondary conclusions in the original report (p3) include the comment that Statistics House was "generally designed and constructed in accordance with the Building Code at the time". Evidence provided to the Panel during this review implies that a number of the measured seatings for the precast floor units were not in compliance with the Concrete Structures Standard of the day. In accordance with the Terms of Reference, the Panel did not establish where in the design and construction process this occurred.

The original report (p3) noted that, "while there were a number of design features that do not appear to conform to the design standards of the time, it is the Panel's view that these were not relevant to the partial collapse". As part of the investigation review, the Panel has reconsidered these non-conformances, which included those brought to its attention by the demolition engineers, and confirmed its opinion that they were not material to the mechanism of partial collapse during the Kaikōura earthquake.

The Panel has concluded that the impact of the short seating is considered of secondary significance for the seismic performance of this building, compared to the vulnerability of the loop bar support detail. A combination of the geometric constraints of the positioning of the loop bar within the precast unit and the need to allow for construction tolerances led to this detail lacking sufficient robustness for use in buildings subject to seismic demands.

Recommendations

Most of the recommendations made in the original report are in progress or have been completed. The evidence brought to the Panel's attention during this review of demolition evidence suggests three further recommendations:

Recommendation 1: Vulnerabilities of buildings with precast concrete components

MBIE should assemble specialist expertise to advise on an industry-wide approach to communicate and mitigate the performance risk of precast concrete floor systems, specifically for:

- building owners, who should be encouraged to retrofit precast floor systems in existing buildings for better protection of building occupants and their asset
- engineers involved in the assessment of existing buildings, who should be aware of the potential for progressive collapse when assessing floor supports
- engineers involved in post-earthquake building evaluation, who should be aware of the need to investigate floor supports for possible concealed damage

Recommendation 2: Demolition considerations of buildings with precast concrete components

MBIE, in conjunction with industry bodies, should notify the building sector about implications of the form of failure of the double tee floor system observed during the demolition of Statistics House, specifically:

- designers, who all need to factor demolition performance into their whole-of-life safety in design obligations
- demolition contractors, who should be aware of the tendency for precast floors to collapse under impact loading and who need to ensure that the demolition methodology has adequately addressed the risk of adverse outcomes resulting from multiple floor level collapse.

Recommendation 3: Construction tolerances

MBIE and industry bodies should review the relevant provisions of the Concrete Structures Standard NZS3101 and the Concrete Construction Standard NZS3109 with a view to addressing better coordination between the design and documentation process and practical construction considerations. This review should primarily look at the tolerance provisions for precast concrete construction with respect to seating requirements. Factors requiring consideration include the:

- sequence of casting (both precast flooring and in-situ support frames) and erection of precast components
- form of support used for the precast flooring units

Annex A: Terms of Reference for the Investigation

Terms of Reference – Performance of Statistics House in 14 November 2016 Earthquake – Seating of Double-Tee Floor Units

Review of the Technical Investigation of Design, Construction and Land influences on the performance of Statistics House in the Kaikōura earthquake on 14 November 2016 with specific reference to new information provided by the engineering consultant engaged to monitor the deconstruction of Statistics House

■ Introduction

Following the magnitude 7.8 Kaikōura earthquake on 14 November 2016 that caused the partial collapse of an intermediate floor in Statistics House, the MBIE Chief Executive undertook an investigation, as provided for in s169 of the Building Act 2004, to understand the factors which led to the partial collapse, in order to help determine whether the building regulatory system is effectively delivering safe buildings and whether there was a need for amendment to regulations or MBIE's power to act. The final product of this investigation was a report by an expert Panel – *Investigation into the performance of Statistics House in the 14 November 2016 Kaikōura Earthquake*.

During the deconstruction of Statistics House it was observed by a consultant appointed by the demolition contractor that, in a number of cases, the measured seating of double-tee floor units was as low as 40mm. This is less than what was specified on the original design drawings for Statistics House, cited in the expert Panel report.

This new information may or may not have an impact on the investigation findings and recommendations if it had been known at the time. On that basis, MBIE considers it is appropriate to refer this information to the original expert Panel, to determine the effect that this new information may have on the original investigation's conclusions and recommendations.

■ Matters for investigation

The purpose of the review of the technical investigation into the performance of Statistics House is to reconvene the investigation to assess the new information provided by the engineering consultant engaged to monitor the deconstruction of Statistics House.

- Whether the new information would have resulted in the Panel reaching any different conclusions or making any different recommendations from the investigation's original conclusions and recommendations.

■ Matters outside the scope of this investigation

The purpose of the reconvened investigation is solely for the purpose of providing an opportunity for the Panel to assess the new information contained in the 5 February 2018 letter and its impact on the conclusions and recommendations of the investigation.

It is not intended that this investigation address issues of culpability or liability arising from the collapse or to make any assessment of whether the original design and construction of the building was in compliance with the Building Code. It is also not intended to address issues relating to the processes followed during, and subsequent to, the original building consent application.

Notwithstanding these exclusions, any relevant Building Code system out-of-scope matters that are discovered by the Panel should be noted and referenced separate to the final memorandum to MBIE.

■ **Expert Panel**

The expert Panel members will be the same as for the original investigation into the performance of Statistics House in the 14 November 2016 Kaikōura earthquake.

■ **Process**

- 1) Collect information
 - a) Obtain information/documentation used in original investigation
 - b) The collection of new information/documentation should include interviews and document reviews with the parties listed below:
 - i) the demolition contractor
 - ii) the engineer engaged by the demolition contractor to monitor the building deconstruction
 - iii) any other party the Panel considers can assist with assessment of the new information
- 2) Assess the information to determine the impact on the original investigation conclusions and recommendations
- 3) Seek feedback from any adversely affected parties on the draft findings
- 4) Report on the findings in a written addendum to the original report.

The investigation is to be conducted in accordance with natural justice. This will require the Panel to provide an opportunity for persons who are, or may be, directly affected by the findings of the investigation to be heard.

■ **Final product**

The final product is a written addendum to the original investigation report outlining whether the Panel considers any changes to its findings or recommendations are necessary in the light of the new information and if so the nature of those changes.

■ **Timing**

Timing will be set by the expert Panel – it is anticipated that once the Panel is convened its written memorandum will be produced within two months.

■ **Cost**

MBIE will meet costs associated with the investigation described above.

Annex B: Letter from demolition engineering consultant

170978c01.docx

5th February 2018

Acting Chief Engineer
Ministry of Business Innovation and Employment

Email [REDACTED]

Attention: [REDACTED]

Dear [REDACTED]

Statistics House, Centreport, Wellington – Seating of Double Tee Floor Units

[REDACTED] were employed as the structural engineering consultant to [REDACTED] for the demolition of the Statistics House, Hinemoa Street, Wellington, which forms part of the Centreport Harbour Quays campus, as we were on a number of other demolition projects for [REDACTED] following the Kaikoura earthquake, including 61 Molesworth Street and the Reading Car Park building.

As part of this commission [REDACTED] reviewed the demolition methodology for this building, reference OPS-PLN-001 Rev A Demolition Methodology -Statistics House, and also undertook monitoring of the demolition as it occurred to ensure that the requirements of the methodology were satisfied.

The initial demolition methodology involved demolishing the building in a generally south to north direction, two bays at a time, having first demolished the southernmost bay starting in the south west corner.

The demolition of Statistics House commenced on 27th December 2017 and the above ground section of the building was largely complete by 24th January 2018 for all practical purposes.

As soon as the demolition started the demolition methodology was required to change, in consultation with [REDACTED]. This change was in part necessitated by the uncontrolled collapse of the double tee floor units which made “sweeping” the floors of debris in a progressive manner impractical.

The change was to demolish the entire western frame of the building, including the floors, up to the first line of the internal gravity beams running longitudinally and then work progressively west to east across the building.

This contrasted with the demolition of the Reading carpark building, for which we were also the contractors engineering advisors, which had a similar double tee floor system, where debris from an upper floor was able to collect on the floor below and be subsequently swept off the building.

In order to understand why the floor units appeared to be collapsing so easily, the seating shelf of the concrete beams, supporting the double tee units, was examined and the seating measured across a number of the intact portions of the beams within the debris. The seating was measured on site to be a minimum of circa 40mm across a number of the beams, enough to conclude that the low seating width identified was not isolated to a singular part of the structure. The 40mm seating is less than;

[REDACTED]

The seating to the double tee units to be 75max 50min

as stated on the original [REDACTED] design drawings.

We have previously been advised that this was amended on the shop drawings so as to be 75mm typical although we have been unable to verify this change.

As we had discovered what we consider to be a material change in the as-constructed building to the seating of the double tee floor units which had failed catastrophically during the Kaikoura earthquake we referred to the Ministry of Business, Innovation and Employment (MBIE) report titled "The Investigation into the Performance of Statistics House in the 14 November 2016 Kaikoura Earthquake" and dated March 2017.

The report contains a section on the support system for the precast floor units from which the following paragraph has been duplicated;

The double tee precast concrete floor units in Statistics House are directly supported on concrete beams with seating specified on design drawings as 75mm maximum and 50mm minimum. This was clarified on pre-cast concrete shop drawings as 75mm typical with no less than 50mm after placement. The seating required to conform with the design standard at the time was 60mm.

The as-constructed seating for these double tee units was assessed as being very different to that understood as being present by the authors of this report.

We approached [REDACTED] and informed them of our findings with regard to the seating of the double tee floor units, and requested that they provide comment. They have verbally confirmed that they did undertake construction monitoring and that all of the applicable Producer Statement Construction PS3's, from the main contractor and precast unit sub-contractor and Producer Statement Construction Review PS4's, from themselves are in place, although we have not viewed these, nor have they been provided.

We did however receive a short memo in the form of an email received from [REDACTED] to demonstrate their changes to their internal processes when undertaking construction monitoring going forward.

Given the findings during the demolition, in particular the very limited seating identified to the double tee floor units very similar to those that failed, we would consider that the limited seating identified on site may materially impact on the findings contained within this report, and therefore the recommendations that have come out of it.

Accordingly we consider it appropriate that this matter be referred to the authors of the MBIE report into this building failure for their consideration.

For your information below are a limited number of photographs which are indicative of what appears to be the limited seating shelf present on the beams which provided support to a number of the double tee units. We would note we have further photographs and site reports should these be required.



Given the importance of what we believe was discovered during the demolition of Statistics House, which clearly the authors of the MBIE report were not privy to, we would be pleased to provide any assistance to the authors of the report that may be required.

We would also request, that, given the various contractual relationships associated with the demolition of this building that this matter be dealt with discreetly. I, and [REDACTED] as a consulting engineering practice, are only raising this due to our ethical obligations in accordance with the Engineering New Zealand Code of Ethical Conduct.

We also understand our obligations to maintain confidentiality. We have raised this matter with [REDACTED] to get their input as to the possible cause. We also raised it with our client [REDACTED] given the apparent impact on the demolition methodology. We have not raised this with Centreport, the building owner, as we have no relationship with this party. We consider the issues associated with Statistics House have been widely published, and we consider the appropriate forum to

raise this matter is with the government department responsible for the report into the partial collapse of this building, and do not consider that this breaches our ethical obligations with respect to confidentiality.

We look forward to receiving MBIE's response on this matter, however in the interim should you have any questions or wish to discuss this please do not hesitate to contact the undersigned.

Yours faithfully

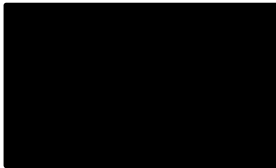
A black rectangular redaction box covering the signature of the undersigned.A large black rectangular redaction box covering contact information, likely a phone number and email address.

Annex C: Technical matters

■ Introduction

There are two primary technical matters that the Panel has considered in light of new information presented:

- construction tolerances and
- impact of seating length.

These are discussed in this annex along with:

- comparison with the current Concrete Structures Standard requirements
- the observed performance of Column C11 during the demolition process
- retrofit details
- considerations for demolition of buildings.

The information presented to the Panel comprised photographs and videos of demolition. None of the information presented allowed direct observation of the precast flooring system in detail.

■ Construction tolerances

The first primary technical matter is the influence of construction tolerance on the actual seating as observed on-site.

The original report contains the statement:

“The double tee precast concrete floor units in Statistics House are directly supported on concrete beams with seating specified on design drawings as 75mm maximum and 50mm minimum. This was clarified on precast concrete shop drawings as 75mm typical with no less than 50mm after placement. The seating required to conform with the design standard at the time was 60mm.”

During the initial investigation the Panel was advised by the structural design engineers that the seating length was 75mm but the Panel was unable to confirm that through examining the shop drawings or the building or at the time. The precast concrete shop drawings show a seating allowance of 65mm. However, the post-demolition observations of seating show that, in a number of instances, this was less than the 60mm required by the Concrete Structures Standard at the time of construction.

Construction tolerances are likely to be a significant factor. In the construction of buildings made from precast concrete, careful consideration of construction tolerances is required. This is because precast concrete components are generally constructed off-site, under controlled conditions, but must be installed alongside components that have been constructed under less favourable conditions. Sufficient allowance must be made for variation in dimensions and locations of reinforcement or embedded elements, to ensure that units are likely to fit and be undamaged during installation when they are positioned in place.

Tolerances for concrete construction are generally specified by NZS3109:1997³, which all designers and builders should generally be familiar with and follow during construction.

³ Standards New Zealand, NZS3109:1997, Concrete Construction

NZS3101:1995⁴ specifically addresses this with respect to allowances for seating of flooring units (cl 4.3.6.4) which requires that the seating be calculated to include allowance for “a reasonable combination of unfavourable tolerances” (refer to Appendix A of this annex). Further guidance is given in the commentary on the factors which should be considered. The commentary states that “when the limitations of 4.3.6.4 b (i) are observed, the effects of movement due to creep and shrinkage on the seating need not be considered further”. That is, the seating specified should be the residual seating after tolerances (casting and erection) but before other time-dependent losses in-service.

Ideally, the precast concrete units would be manufactured after the in-situ components are cast, allowing an accurate site measure and adjustment of the length of the flooring unit to suit. In practice, this is not feasible as it would negate one of the major benefits of prefabrication, which is saving time by completing work off-site. Instead, shop drawings are generally prepared by the precast subcontractor and reviewed by the main contractor and the designers, allowing all parties to consider the required construction tolerances. The precast elements (in the case of Statistics House, comprising precast beams and double-tee flooring units) are manufactured well before installation and stored off-site until the construction has reached the stage that they are required to be installed.

There are a number of variable dimensions that may impact on the fit of the units and therefore the available seating. Refer to Figure 1.

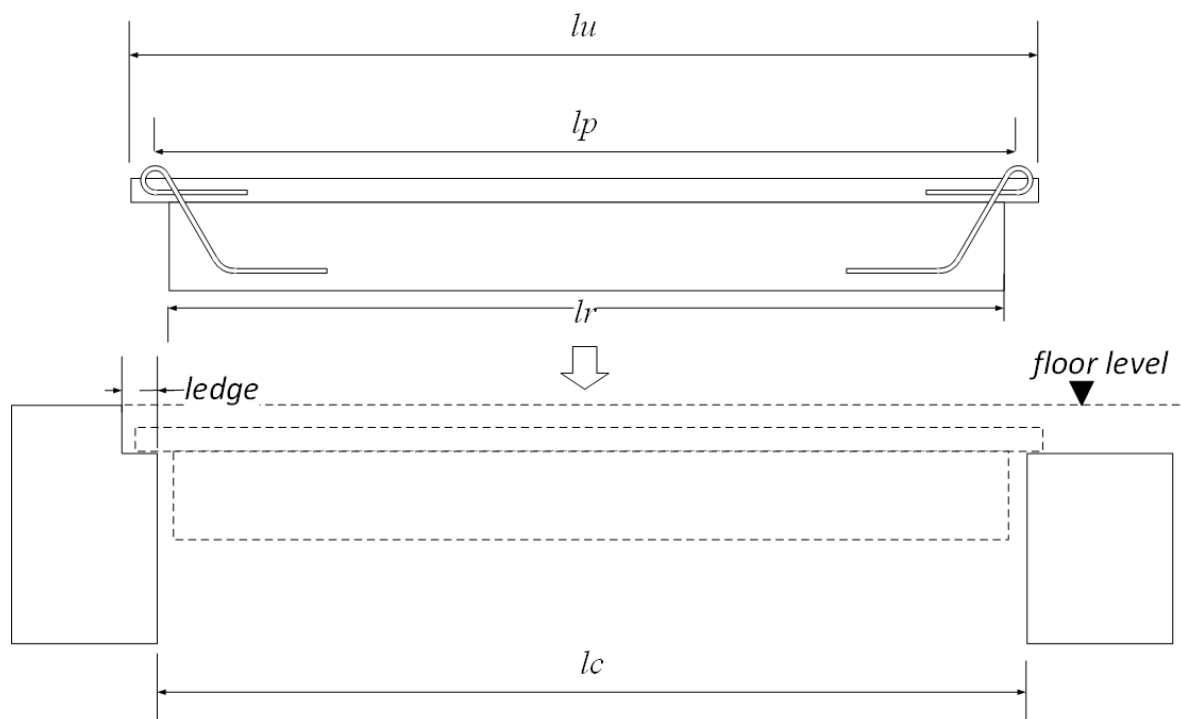

Figure 1: Precast tolerances for Statistics House (not to scale)

There are four critical measurements, as follows:

l_u , the overall length of the precast flooring unit

l_p , the length between the centres of the loop bars

⁴ Standards New Zealand, NZS3101:1995, Concrete Structures Standard, Part 1, The Design of Concrete Structures & Part 2, Commentary on the Design of Concrete Structures

l_r , the length of the double-tee ribs

l_c , the clear length between the supporting beams.

Of these dimensions, the first three are functions of the double-tee floor unit manufacturing process. The fourth, although relating to precast elements (the supporting beams) is determined as an outcome of the erection of the precast beams onto in-situ columns, and is determined by on-site practices. The maximum available seating is determined as a function of the length of the precast flooring unit and the actual clear space between the beams after they are cast into the columns.

The final factor to be considered is the installation process of the flooring units. The units (weighing up to approximately 5.5t) are craned into place and, depending on the skill of the construction staff, will be levered into position on the supporting ledges of the beams. In practice, there will always be some variation in the seating length at the ends of the units.

Hence the final seating of the nib at each end of the unit will reflect the cumulative tolerance from a number of sources, including primarily the:

- length of the unit
- available width of the precast beam ledges
- erection and casting in of the supporting beams
- actual location of the double tee within the gap between the supporting beams.

Finally, the nature of the support itself should be considered. With a flange-supported double tee, the primary supporting element is the nib of the double tee, reinforced by the loop bar hanger. The location of the loop bar is determined by the requirement for cover to the angled leg of the loop bar from the throat of the double tee (where the rib intersects the flange); in this case, it is a minimum of 15mm (the minimum cover allowed under NZS3101 for 60MPa concrete in an interior environment). Given the centre of the reaction R from the weight of the units must intersect at the centre of the loop bar, the critical dimension that determines this location is the gap between the end of the rib and the supporting beam. This is illustrated in more detail in Figure 2.

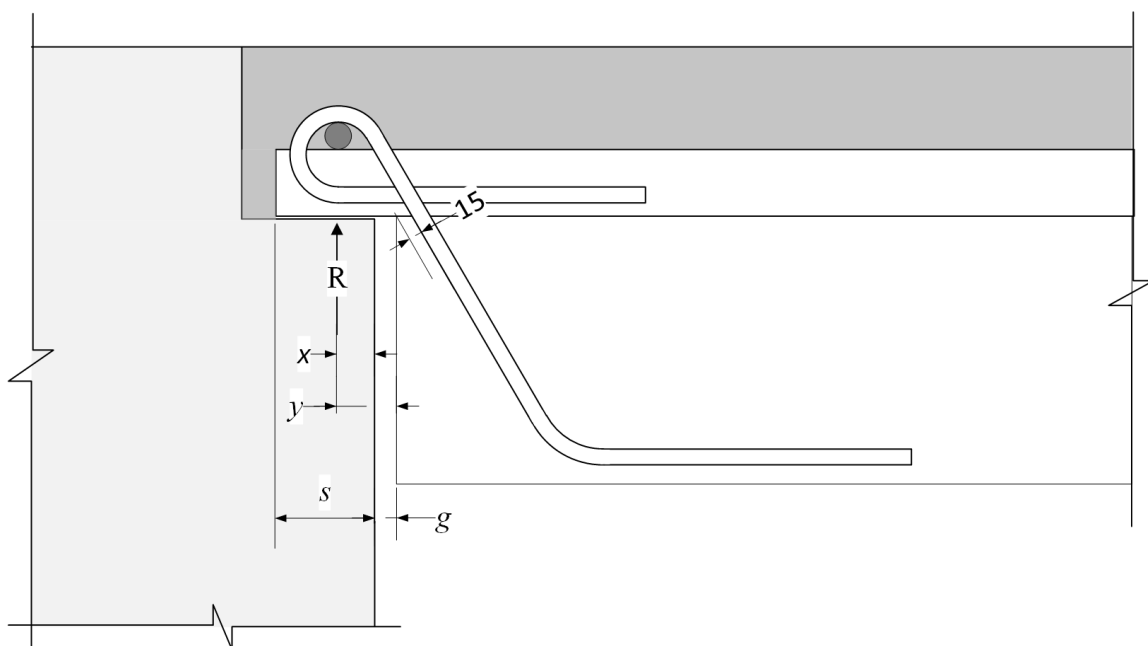

Figure 2: Detail of loop bar at support

With the geometry of the loop bar and the cover requirement taken into account, the distance, y , from the reaction R at the centre of the loop to the end of the rib is approximately 35mm. (If an inclination of the reaction of say 15 degrees from vertical is assumed, this moves the reaction to approximately 48mm from the end of the rib).

In its original investigation the Panel did not attempt to verify any of the details from the shop drawings or the as-built condition for Statistics House. The shop drawings and the original design drawings have been used to determine the dimensions in the table below (for the outer bays only), assuming that everything is located in its ideal position (i.e. before the impact of construction tolerances):

Element		Length	Formulation
Double tee total length	lu	10,780mm	
Double tee rib length	lr	10,620mm	
	nib	80mm	$(lu-lr)/2$
Support beam total clearance	lc	10,650mm	
Ideal seating of nib	s	65mm	$(lu-lc)/2$
Seating required by NZS3101:1995	s_{min}	60mm	$L/180$
Allowance for construction tolerance		+/- 5mm	$s-s_{min}$
End of rib to centre of reaction R	y	35mm	By geometry
Gap from end of rib to beam	g	15mm	$(lc-lr)/2$
Distance of reaction R from edge of support	x	20mm	$y-g$

Key selected tolerances from NZS3109 are as listed below:

Length of precast members (critical dimensions of ledge supports)	+/- 10mm
Insert location in precast element	+/- 8mm
Width of precast beams	+/- 5mm
Location of element in plan or elevation (from nearest reference line)	+/- 10mm

From this it can be seen that although there was some allowance (+/- 5mm) for tolerance in the ideal dimension of the precast flooring, it was less than the potential cumulative effects of the acceptable tolerances of the construction.

Had the specified seating been 75mm, as was indicated at the time of the initial report, the available seating tolerance would have been +/-15mm. This implies that the units would be more likely to achieve the minimum seating of NZS3101:1995, noting that the Standard requires consideration of "a reasonable combination of adverse tolerances," which does not imply a full summation of all of the worst case outcomes.

■ The impact of seating length

The second primary technical matter is the impact of the seating width on either the initial failure during the Kaikōura earthquake or the reported failure during the demolition process. That is, ignoring the requirements of design Standards, did the short seating as observed have any significant influence on the behaviour of the floor units during the earthquake and do the original report conclusions require revision as a consequence of this new information?

The mechanism of failure of the concrete nib around the loop bar during the earthquake was presented in the original report (p25–26). In summary, the rotation of the units during earthquake shaking initiated cracking around the ‘knuckle’ of the loop bars. This effective shortening of the units exacerbated the effect of beam elongation resulting in loss of support and dropping of some floor units.

After viewing videos provided by the demolition contractors and demolition engineers the Panel discussed the demolition failure mechanism with both parties. The Panel’s opinion is that the failure observed during demolition is likely to have followed one of the forms of failure proposed by the Structural Engineering Society of New Zealand (SESOC) study of 2009⁵. In this case the sudden overloading from the impact of material falling from above would have resulted in immediate failure at the loop bar as indicated in Figure 3. The tensile force generated across the unreinforced construction joint would have caused failure of the concrete in tension, leading to the loop bar bending up and the floor units subsequently falling. The damaged state of the building after the earthquake, including the presence of beam elongation, may have contributed to the eventual failure of the units during demolition.

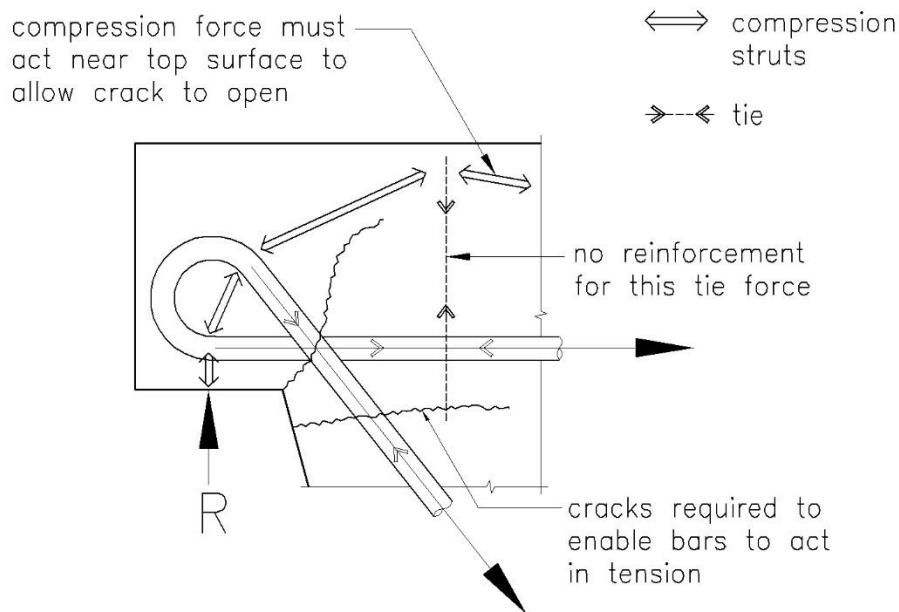

Figure 3: Strut and tie analysis of flange-supported double-tee (from Figure 5, SESOC Journal)

Therefore the mechanism of failure during the Kaikōura earthquake and during demolition cannot be directly compared.

⁵ Hare J., Fenwick R., Bull D., Built R., Fulford R. Precast Double Tee Support Systems, SESOC Journal Vol 22, No. 1, April 2009

It is unlikely that the nib length would have had a significant influence on the failure mechanisms of either the Kaikōura earthquake or the subsequent demolition. This is because the initiation of failure in both cases is most likely to have resulted from the loop bar configuration.

The critical factor is the location of the loop bars relative to the supports. As noted previously, if everything conformed exactly to the documentation, the centre of reaction of the loop bar would have been 20mm from the support. Even if the rib was hard to the beam (which in some cases it may have been), this would have put the centre of the loop still only 35mm from the support face, effectively on the cover concrete of the supporting beam, and not suitable to provide support for either seismic actions or shock loading such as from demolition.

This means that even in the most favourable of circumstances the detail is reliant on the nib and therefore tensile actions in the concrete. This is generally not acceptable either under NZS3101 or through analysis from first principles.

Had the nib been any longer, the failure observed following the Kaikōura earthquake would have been no different. As it was, the ends of the nibs that broke off were observed to have remained in place on the beam ledge after the double-tee units had fallen. A longer nib would, if anything, have potentially resulted in a greater lever arm for the nib to crack at the knuckle.

■ Influence of seating during demolition

Even if the seating width had been greater, the units would have remained vulnerable to shock loading, such as during demolition. Regardless of the seating width, the principle load path would have to follow the general arch profile as shown above in Figure 3. It would still have to intersect at or near the centre of the loop and would cause a tensile force across the interface of the precast flooring and topping.

With the accumulation of debris on the floor (which was not possible to sweep clear over the majority of units) and the significant shock loading, the entire support mechanism was likely to be overwhelmed. This is probably exacerbated in the case of flange-supported double tees by the fact that the entire support mechanism for a double tee is concentrated at two points at each end of the units, as illustrated in the hatched areas of Figure 4 below, where the loop bar hangers are located.

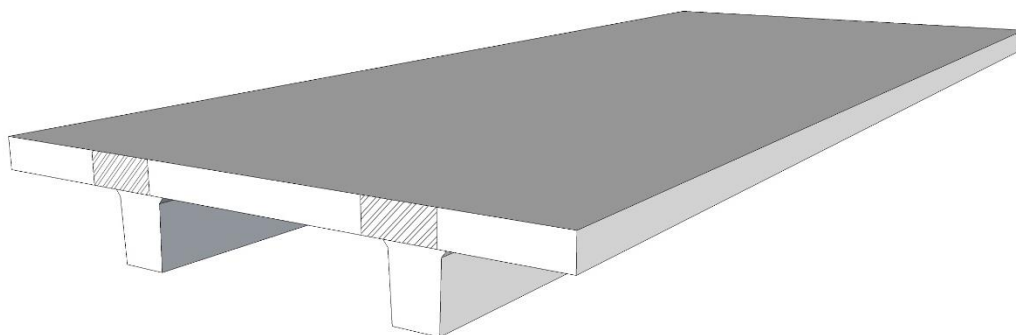

Figure 4 Points of support for double-tee floor unit

■ Comparison with the requirements of the current Concrete Structures Standard for design

The Concrete Structures Standard, NZS3101, has been updated several times since the version in use at the time of the Statistics House design. The most recent version, NZS3101:2006⁶ issued August 2017, has revised seating requirements for precast flooring. It requires seating for normal conditions (cl 18.7.4.3) for double-tee floor systems to be the greater of:

- 1) at least 1/180 of the clear span
- 2) 75mm
- 3) the summation of the calculated bearing length plus allowances for spalling of both the end of the flooring unit and the support, plus allowances for creep, shrinkage and thermal movement.

In addition, it requires the designer to consider seismic effects (cl 18.8). A worked example of a ductile framed structure (similar to Statistics House) in the commentary to the Standard suggests a seating of 140mm, which could be reduced by armouring both the back face of the flooring unit and the face of the seating ledge.

It is implicit in this methodology that the nib of the unit can maintain its integrity through the imposed rotations that accompany the elongation. However, this rotation is what is believed to have caused the cracking at the knuckle of the loop bar, as indicated in the first Statistics House Investigation report. Hence, although the revised seating calculation of NZS3101:2006 will result in greater seating, unless the flange support detail has sufficient robustness to also deal with the rotation, it will not achieve the Building Code objectives. This would require either a fully reinforced end that can also engage with the topping to resist the tie forces postulated in the SESOC report, or a mechanical support such as a Cazaly hanger. The alternative is a full depth rib-supported system. It should be noted that on 3 April 2018, MBIE issued a warning about the use of the loop bar hanger detail.

■ Observed cracks in Column C11

The detailing of the reinforcement in the in-situ splice regions immediately adjacent to the corner columns was reviewed by the Panel during preparation of the original report. The northwest corner column, C11, was immediately adjacent to the floor units that collapsed during the Kaikōura earthquake. At that time, the Panel concluded that while the detailing employed was not fully compliant with the Standard of the day in some respects, this would have had no influence on the failure. It was felt that the joint could degrade and lose capacity in a major earthquake but that would be a result of significant north–south direction actions. Post-earthquake observation of the building did not indicate north–south displacement leading to significant damage.

Pictorial evidence was presented to the Panel of this joint during the demolition process, showing significant cracking in a pattern consistent with the failure mode expected. However, the photo had been taken after substantial demolition activity around the beam. In comparison with photographs from the original investigation, it appears that the majority of this damage is most likely to have been as a result of demolition activities. The Panel has reaffirmed the original conclusion that this detail had no significant influence on the localised floor collapse during the Kaikōura earthquake.

⁶ Standards NZ, NZS3101: Part 1:2006, amendments 1,2&3, part 1, issued August 2017, gazetted in NZBC B1/VM1 amendment 16 on 3 April 2018.

■ Retrofit details

During the interview between the Panel and the demolition engineers, concerns were raised over the performance of the retrofit detail that was in the process of being progressively installed in Statistics House (prior to the Kaikōura earthquake). The evidence presented to the Panel was that the brackets had pulled out of the supporting beams. Reference was made in the interview with the demolition engineers to more conventional shelf angle supports or similar that had been installed in the Reading Cinema car park and that remained attached to the beams during demolition.

The detail used in Statistics House was specific to the situation of its use – it was intended to allow a significant amount of elongation during lateral loading such as an earthquake without restraint of the beam. Therefore, it was articulated as illustrated in Figure 5 below.

This is a distinctly different case to demolition loading, where the double tees either had the outer support beam physically removed or were failing at the ends under the shock loading of debris falling from above. As the bracket was physically attached to both the double tees and the support beams a failure had to occur in either the fixings or the bracket itself, as the bracket was forced into tension. There is not sufficient evidence to draw any conclusions on the precise mode of failure, but it is likely that the instantaneous overload was much greater than the bracket was designed for.

In reviewing the detail and the information presented, the Panel has no adverse comment on the likely performance of this bracket under the loading conditions for which it was originally designed. The Panel would not necessarily have expected to see the brackets remaining fixed to the beams following demolition, nor for the brackets to have had sufficient capacity to prevent failure of the floor under the cumulative weight of debris and shock loading.

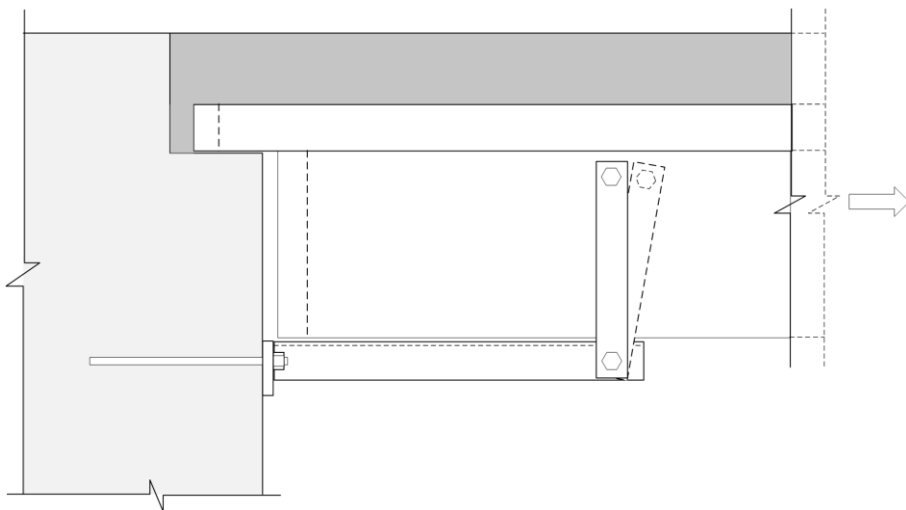

Figure 5: Retrofit detail used at Statistic House

■ Considerations for demolition of buildings

The sudden failures of the double tees during demolition flag a potential issue for designers, in the context of 'safety in design' considerations. The Health and Safety at Work Act 2015 requires (s 39 (2)(e)(i)) that:

"The designer must, so far as is reasonably practicable, ensure that...the structure is designed to be without risks to the health and safety of persons—...who carry out reasonably foreseeable

activity... in relation to—the manufacture, assembly, or use of the structure for a purpose for which it was designed, or the proper demolition or disposal of the structure...”

The demolition contractor clearly stated that buildings with flange-supported double tees are prone to their floor system readily collapsing during the demolition process. In low to medium-rise buildings, this may be manageable through careful sequencing of work, positioning of equipment and cordoning of work faces, but could be a problem in other circumstances or where a contractor is not experienced with this system.

Designers should be alerted to this issue and in cases where eventual demolition may not be achieved with sufficient levels of safety, alternative floor systems may be required.

Appendix A – Referenced Code Clauses from NZS3101:1995

4.3.6.4

For precast floor or roof members supported only by bearing onto a seating, with or without the presence of a cast-in place topping and/or continuity reinforcement, the following requirements shall be satisfied:

- (a) The bearing strength for the ultimate limit state at the contact surfaces between supported and supporting members and at intermediate bearing elements shall not exceed that given by 8.3.5.
- (b) Unless shown by analysis or test that the performance of alternative details will be acceptable, design shall provide for the following minimum seating requirements:
 - (i) Each member and its supporting systems shall have design dimensions selected so that, under a reasonable combination of unfavourable construction tolerances, the distance from the edge of the support to the end of the precast member in the direction of its span is at least 1/180 of the clear span but not less than:
 - For solid and hollow-core slabs 50 mm
 - For beams or ribbed members 75 mm
 - (ii) Bearing pads at unarmoured edges shall be set back a minimum of 15 mm from the edge, or at least the chamfer dimension at chamfered edges.

36

C10.4.3

Frame dilatancy is of concern where precast concrete floor units have minimal support on beams^{10.7}.

Adequate support is considered to be provided where precast floor units have either a minimum seating length in accordance with the requirements of 4.3.6.4, or have hanger bars tied into the support that are sufficiently ductile to prevent collapse of the floor units at the maximum anticipated inelastic beam elongation.